



High Performance Vertical Turning Center

PUMA

400/M/P • 400-2SP



Doosan Machine Tools

PUMA V400 SERIES

The compact vertical turning center has a small footprint and is ideal for heavy-duty machining operations and for achieving long term accuracies. Its powerful spindle drives, meehanite casting and integral box guideway construction provide unsurpassed stability and rigidity.

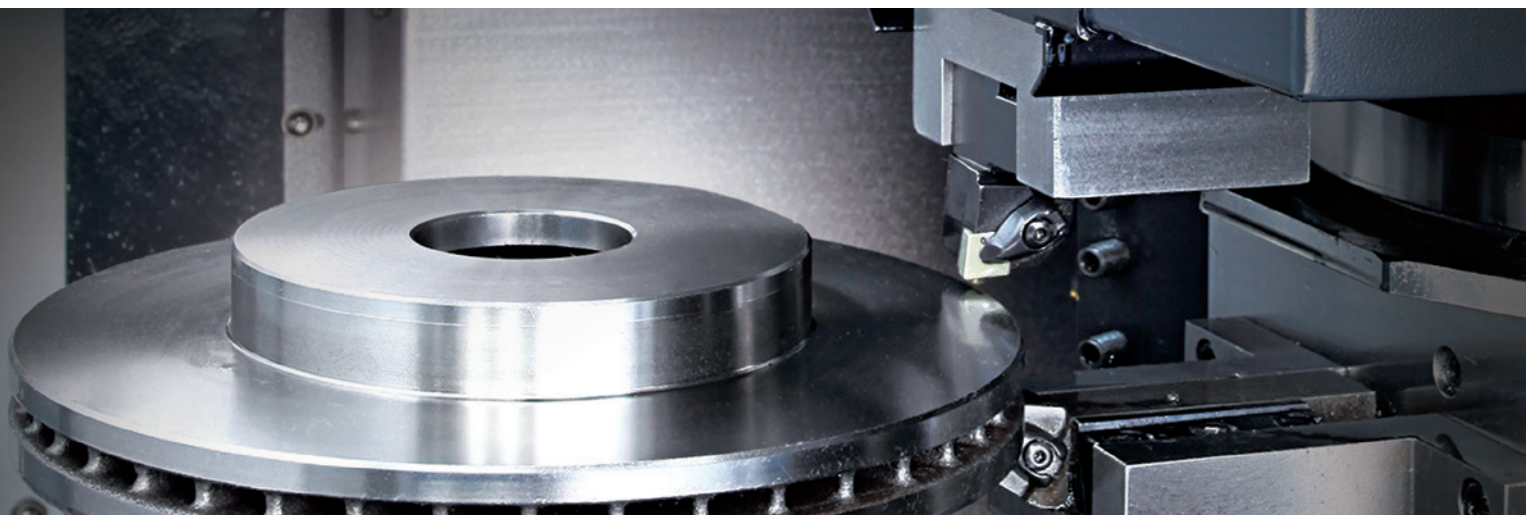



ENHANCED TURNING CAPACITY

These machines have exceptional machining capabilities and are able to deliver the optimum in productivity for customers.

HIGH RELIABILITY

To facilitate heavy duty machining and optimize chip flow, the machine's base has been streamlined.

USER FRIENDLY DESIGN

The bed structure has been redesigned to enable high chip volumes to be disposed of - quickly and efficiently. For operator comfort and convenience the height of the operation panel can be adjusted.

BASIC STRUCTURE | MACHINING AREA

The machine's integral box guideway bed design ensures vibration-free performance and facilitates heavy duty and high precision cutting.

Robust bed construction

A Meehanite cast iron bed and integral box guideways provide the rigid foundation needed for superior precision, heavy duty cutting and reliability. The heavily-ribbed and innovative bed design provides unsurpassed rigidity and, as a result, delivers exceptional accuracies and repeatability's and superior surface finishes.

Travel distance (X/Z axis)

268/488 mm
10.55 / 19.21 inch

Rapid traverse (X/Z axis)

20/24 m/min
787.4 / 944.9 ipm

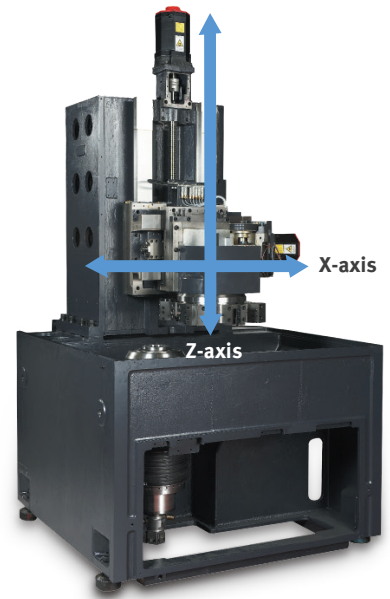

PUMA V400P

The PUMA V400P vertical turning center is a productivity powerhouse with Roller-type LM guides, impressive rapid rates and fast acceleration/deceleration.

Power of axis motor (X / Z axis)

3/7 kW

Rapid traverse (X / Z axis)

24 m/min

Roller type LM guideways

Roller type LM guideways and upgraded servo motors along with a Meehanite cast iron bed with rigid heavy-rib structure, deliver outstanding productivity.

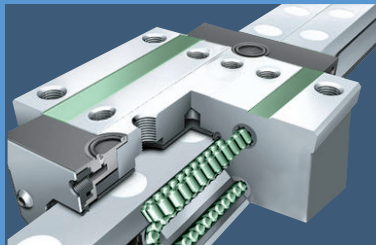

Machining time for brake disc



* Internal test result

MACHINING AREA

Wide machining area for larger/more diverse workpieces.

(A) Max. turning diameter

PUMA V400(P) / M

Ø496/420 mm
19.53/16.54 inch

(B) Max. turning length

PUMA V400(P) / M

461/400 mm
18.15/15.75 inch

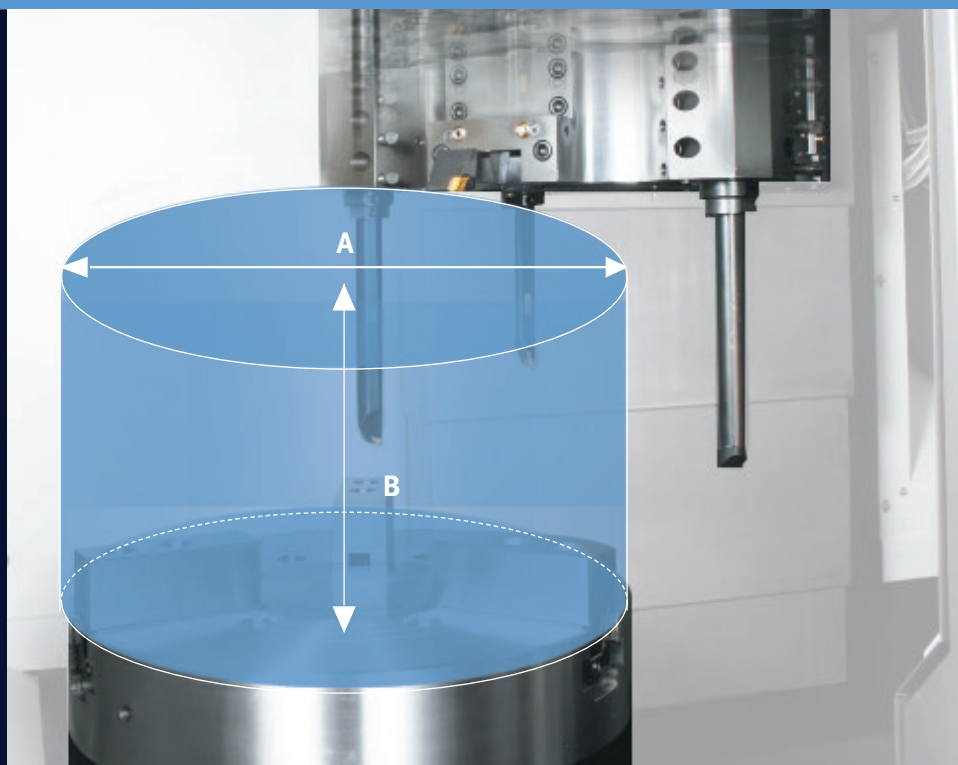

SPINDLE | TURRET

High reliability and rigidity with an improved base and spindle motor assembly. The cartridge type spindle with A2#8 spindle nose is highly capable and is easy to maintain. The extremely rigid coupled bearing assembly supports heavy workpieces and helps reduce thermal growth over long machining runs and extended operation.

Max. spindle speed

3000 r/min

Max. spindle power (S6 25%)

26 kW 34.9 Hp

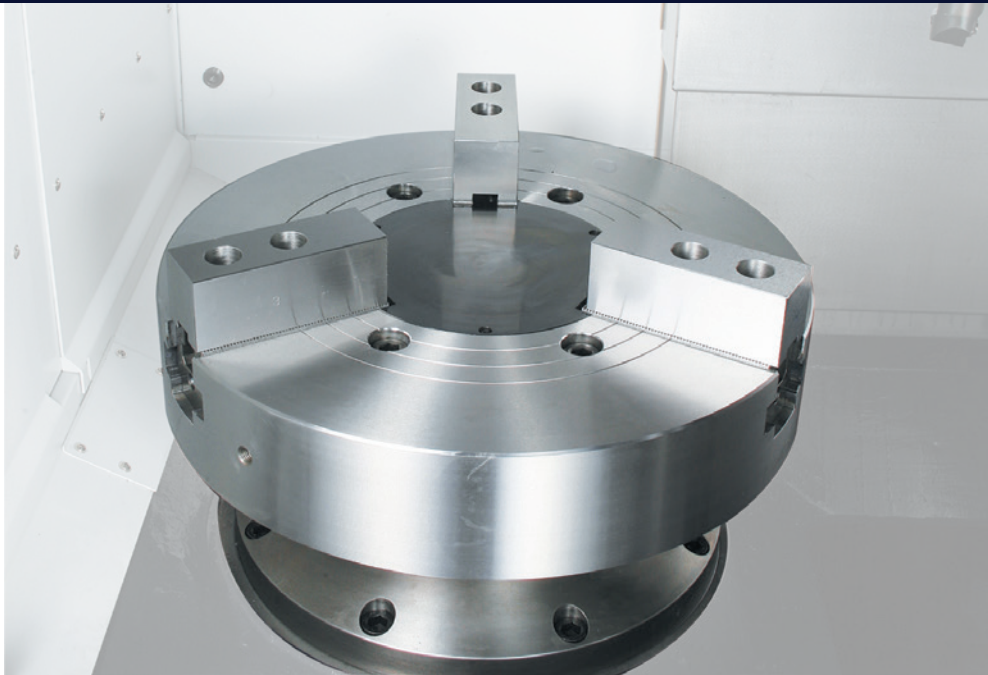

TURRET

The servo turret facilitates faster indexing and accurate positioning.

The large 12 station heavy duty turret features a large diameter Curvic coupling and has a heavy duty design with unsurpassed rigidity. Turret rotation, acceleration and deceleration etc., are all controlled by a reliable high-torque servo motor. Unclamping and rotation are virtually simultaneous. The machine's fast indexing response reduces the total part cycle times.

Index time (11-station swivel)

0.15 s

No. of tool station

PUMA V400(P) / V400-2SP

12/12+12 ea

PUMA V400 / V400-2SP

8/8+8 ea OPTION

PUMA V400M : BMT65P

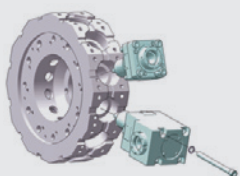

Rotary tool head

The rotary tool head ensures high rigidity and accuracy by simultaneously facilitating dual contact between the rotary tool head face and the tool holding insert (called Preci-flex adapter) flange face as well as its the tool head pocket taper.

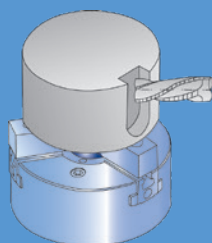

Collet application



Preci-flex adapter application



STANDARD | OPTIONAL SPECIFICATIONS

A range of options is available to suit individual requirements.

Description	Features	PUMA V400 series
Chuck (LEFT / RIGHT)	305 mm (12 inch)	●
	380 mm (15 inch)	○
	Hydraulic chuck & actuating cylinder	●*1)
	None	○
Jaw (LEFT / RIGHT)	Soft Jaws	●
	Hardened & Ground Hard Jaws	○
Chucking option	Dual Pressure Chucking	○
	Chuck Clamp Confirmation	○
Coolant pump	1.5 bar	●
	4.5 / 7 / 10 / 14.5 bar	○
Coolant options	High Coolant Interface	○
	Oil Skimmer(Belt type)	○
	Coolant chiller(circulation type) ²⁾	○
	Coolant Pressure Switch	○
Chip Conveyor	Side chip conveyor(Left)_Hinged type	○
	Side chip conveyor(Left)_Magnetic scraper	○
	Rear chip conveyor_Hinged type	○
	Rear chip conveyor_Magnetic scraper	○
Chip processing options	Chip Bucket (220L / 300L)	○
	Flushing coolant	○
	Air blower	○
	Air Gun	○
	Coolant Gun	○
Automatic configuration	Auto door with safety edge	○
	Automatic side door	○
	Tool Setter	○
	Work & Tool Counter	○
Robot Interface	PMC I/O MODULE TYPE	○
	PROFIBUS-DP TYPE	○
Customized Special Option	Coolant Level Switch : Sensing Level - Low	○
	Quick Change Tooling(CAPTO)	○
	High Torque Spindle With Gear Box	○
	Straddle Tool_Servo Type	○
	Coolant Pump_4.0 kW_2.0 Mpa	○
	Automatic Top Door	○
	Automatic Side Door	○
	Flushing Coolant_Special Specification	○
	Raised Column_50 mm	○
	Chuck Type_4 Jaw_T-Slot	○
	Additional Hydraulic A/B Line	○
	Rotary Cylinder_For Air Limit Sensing	○
	Raised Level Plate_110 / 160 / 200 mm	○
	Rotary Type Window Wiper_Electrical	○

Please contact your Doosan Machine Tools representative for detailed machine information.

1) In case of chuck specification change, it may be necessary to replace the chuck cylinder.

2) Coolant chiller is highly recommended to prevent temperature rise and minimize thermal deformation, when using a water-insoluble coolant or high-pressure coolant system of which the power is over 1.5 kw.

● Standard ○ Optional X N/A

DOOSAN FANUC i PLUS

Doosan Fanuc i Plus maximizes customer productivity and convenience.

15" Screen + New OP

Doosan Fanuc i Plus' operation panel enhances operating convenience by incorporating common-design buttons and layout. It features a Qwerty keyboard for fast and easy data input and operation.

Doosan Fanuc i Plus

- 15-inch color display
- Intuitive and user-friendly design

USB and PCMCIA card QWERTY keyboard

- EZ-Guide i standard
- Ergonomic operator panel
- 2MB Memory
- Hot keys



iHMI touchscreen OPTION

iHMI provides an intuitive interface that uses a touchscreen for quick and easy operation.

Range of applications

Providing various applications related to planning, machining, improvement and utility, for customer convenience.

NUMERIC CONTROL SPECIFICATIONS

FANUC

Division	Item	Specifications	PUMA V400 / P	PV400M	PV400-2SP
			Doosan Fanuc i (F0i-F Plus)	Doosan Fanuc i (F0i-F Plus)	Doosan Fanuc i (F0i-F Plus)
Controlled axis	Controlled paths		1 Path	1 Path	2 Path
	Controlled axes		2 (X,Z)	3 (X,Z,C)	4 (X1,Z1+X2,Z2)
	Simultaneously controlled axes		2 axes	3 axes	2 axes (each path)
Data input/output	Fast data server		○	○	○
	Memory card input/output		●	●	●
	USB memory input/output		●	●	●
	Larger capacity memory_2GB	Note *2) Available Option only with 15" Touch LCD (iHMI Only)	○ *2)	○ *2)	○ *2)
Interface function	Embedded Ethernet		●	●	●
	Fast Ethernet		○	○	○
	Enhanced Embedded Ethernet function		●	●	●
Operation	DNC operation	Included in RS232C interface.	●	●	●
	DNC operation with memory card		●	●	●
Program input	Workpiece coordinate system	G52 - G59	●	●	●
Feed function	AI contour control I	G5.1 Q_, 40 Blocks	●	●	●
	AI contour control II	G5.1 Q_, 200 Blocks	○	○	○
Operation Guidance Function	EZ Guidei (Conversational Programming Solution)		●	●	●
	iHMI with Machining Cycle	Note *1) Only with 15" Touch LCD standard	○ *1)	○ *1)	○ *1)
	Multi path function	Supporting 2 or 3 path machine	●	●	●
	EZ WORK		●	●	●
Setting and display	CNC screen dual display function		●	●	●
Network	FANUC MTConnect		*	*	*
	FANUC OPC UA		*	*	*
Others	Display unit	15" color LCD	●	●	●
		15" color LCD with Touch Panel	○	○	○
	Part program storage size & Number of registerable programs	5120M(2MB)_1000 programs	●	●	●

● Standard ○ Optional X N/A ⊕ Available

POWER | TORQUE

FANUC

PUMA V400 / M / P

Max. spindle speed : **3000** r/min

Max. power : **26** kW
34.9 Hp

Max. torque : **1050** N·m
774.9 ft-lbs

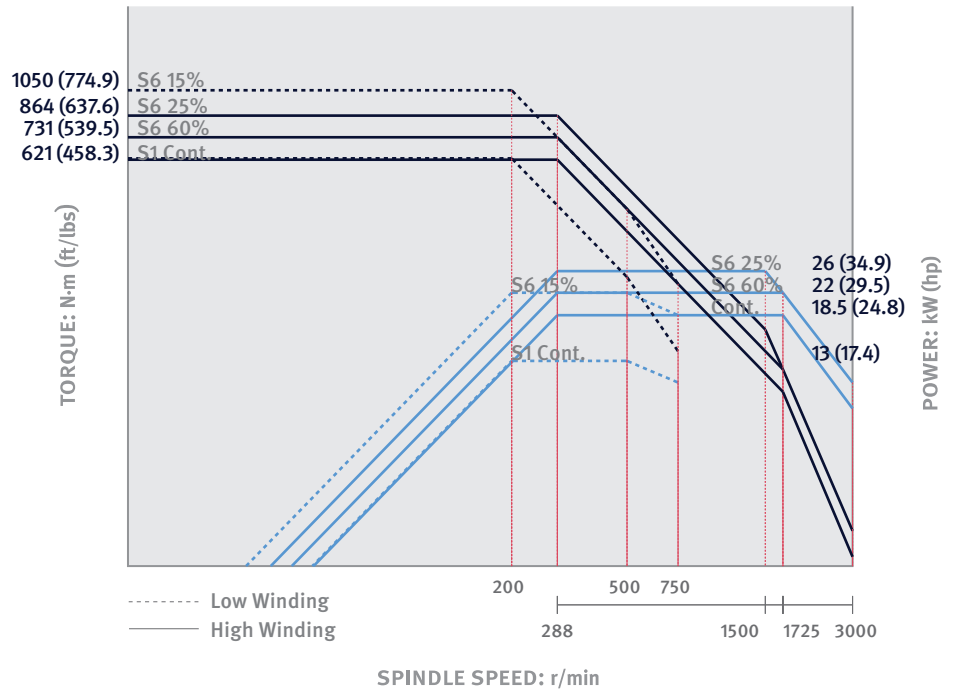

Rotary tool_PUMA V400M BMT65P rotary spindle

Max. spindle speed : **4000** r/min

Max. power : **5.5** kW
7.4 Hp

Max. torque : **47** N·m
34.7 ft-lbs

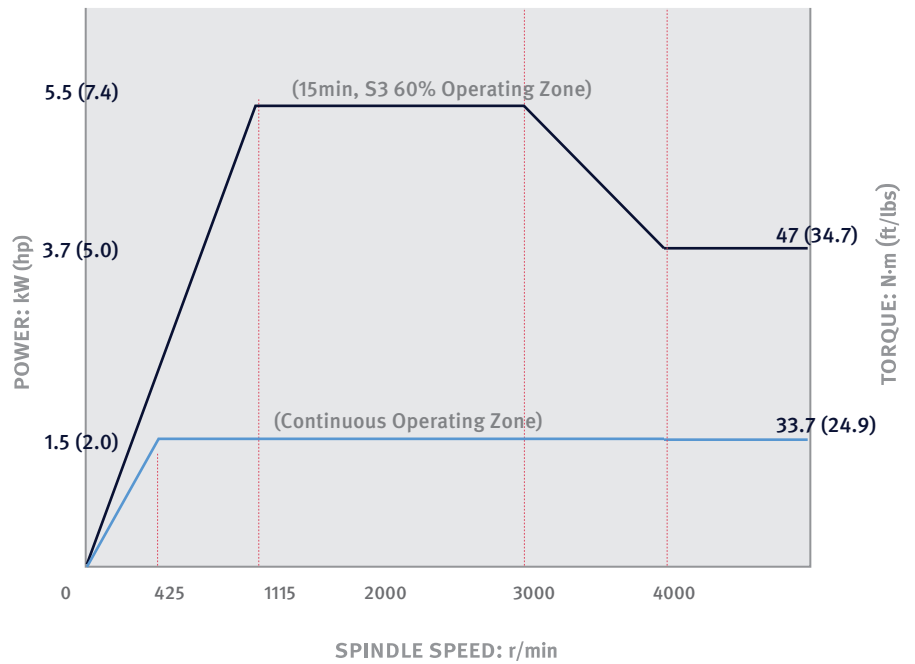

EXTERNAL DIMENSIONS

Unit : mm (inch)

PUMA V400/M/P

TOP

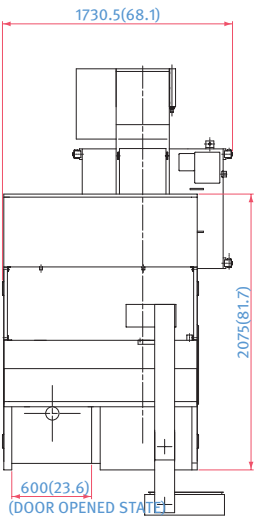

FRONT

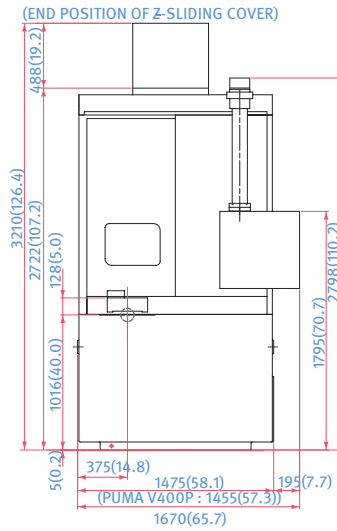

SIDE

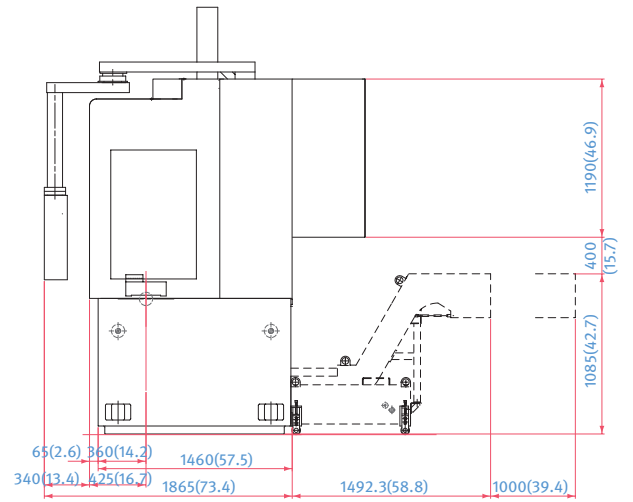

PUMA V400-2SP

TOP

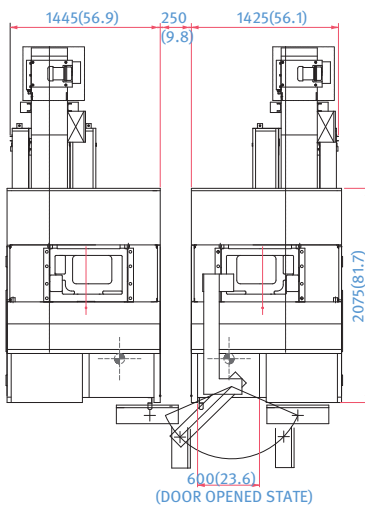

FRONT

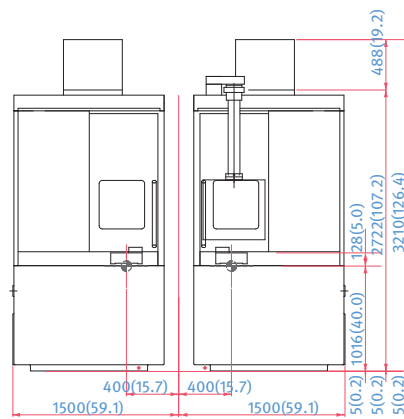

SIDE

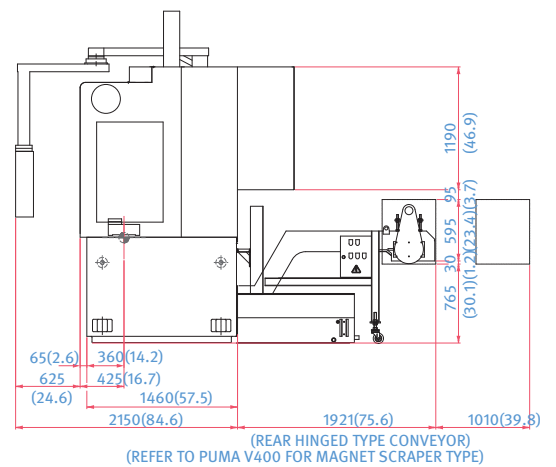

* Some peripheral equipment can be placed in other areas.

TOOLING SYSTEM

Unit : mm (inch)

PUMA V400 / M / P

Standard

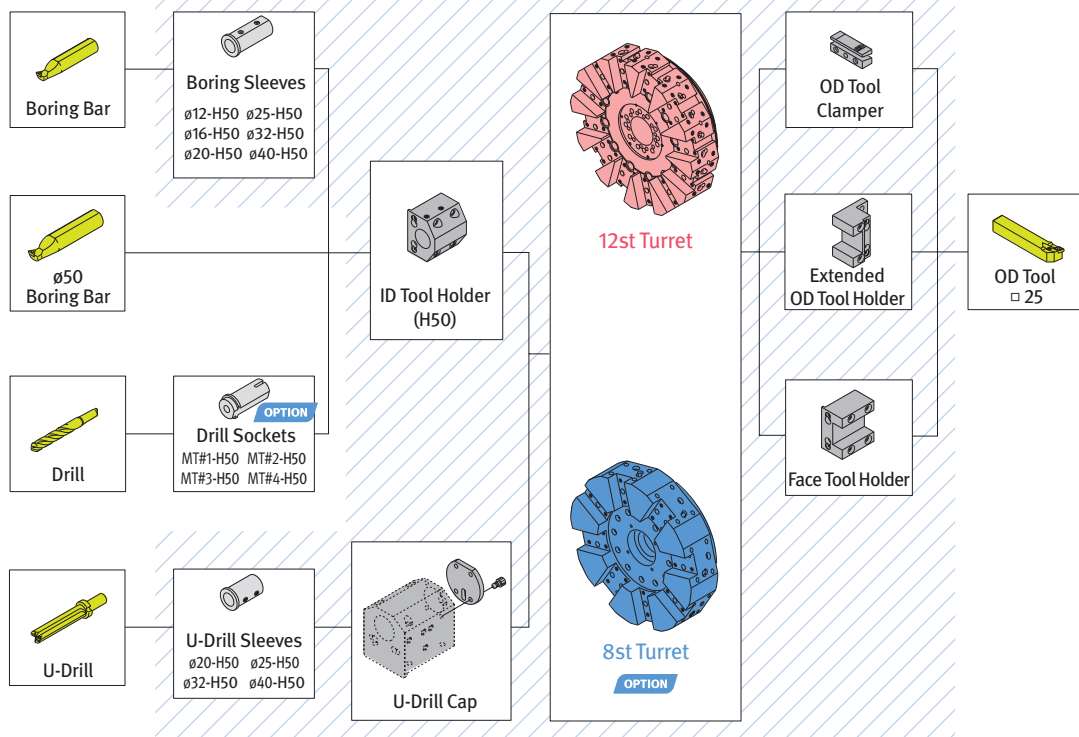

PUMA V400-2SP

Standard

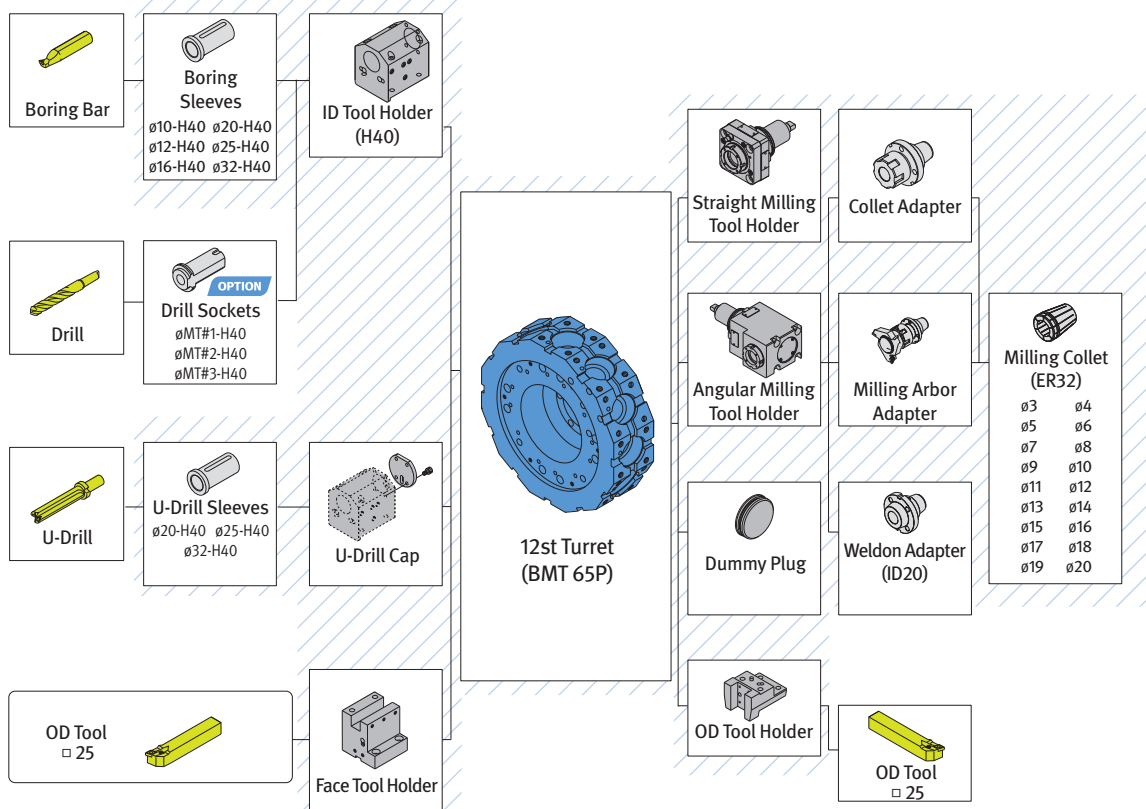

TOOL INTERFACE

Unit : mm (inch)

PUMA V400 / P / V400-2SP

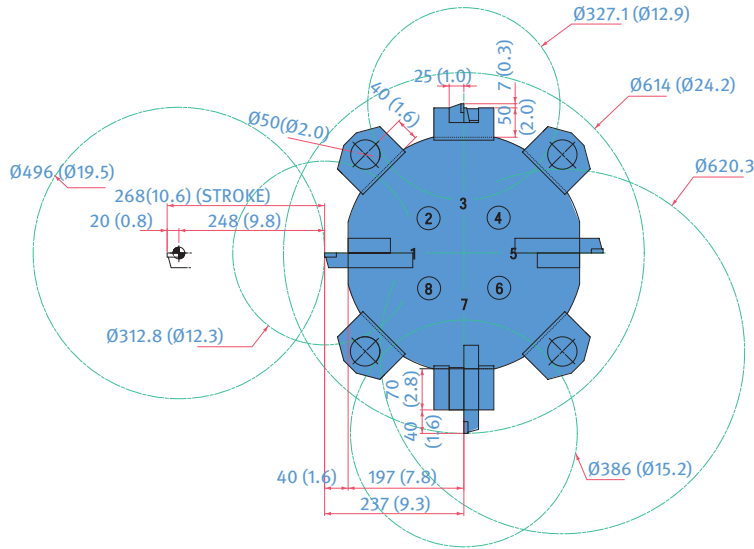
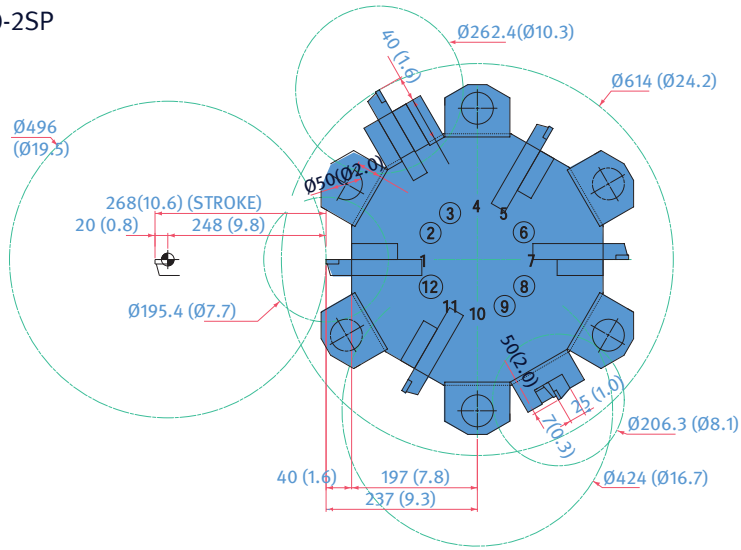

PUMA V400M

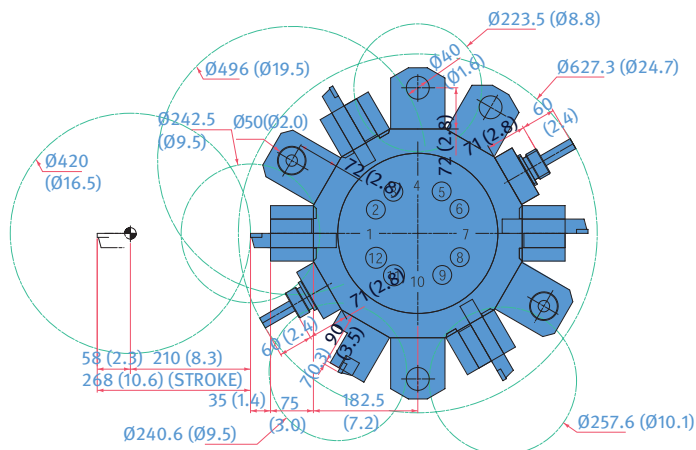

WORKING RANGE

Unit : mm (inch)

PUMA V400 / P / V400-2SP

OD TOOL HOLDER

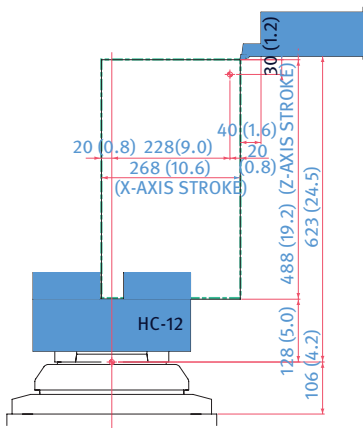

EXTENDED OD TOOL HOLDER

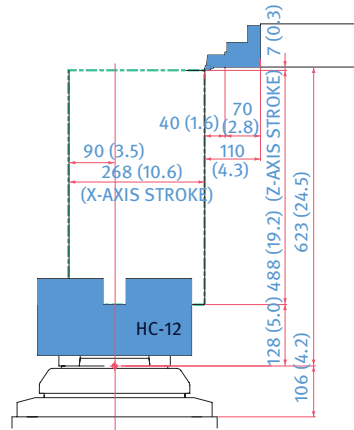

ID TOOL HOLDER

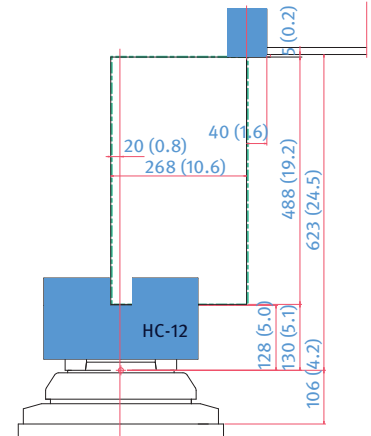

PUMA V 400M

OD TOOL HOLDER

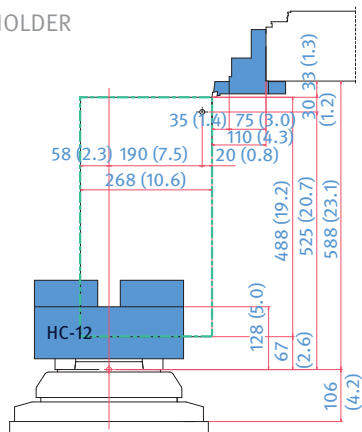

ID TOOL HOLDER

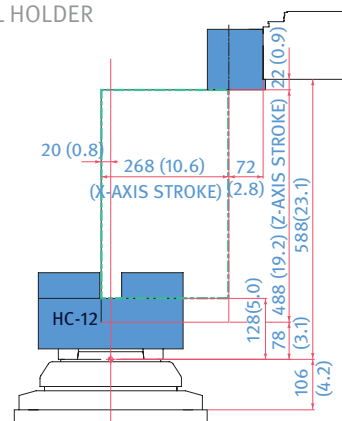

STRAIGHT MILLING TOOL HOLDER

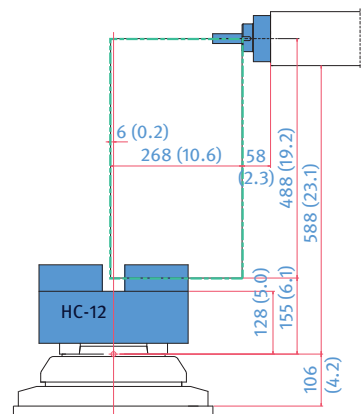

ANGULAR MILLING TOOL HOLDER

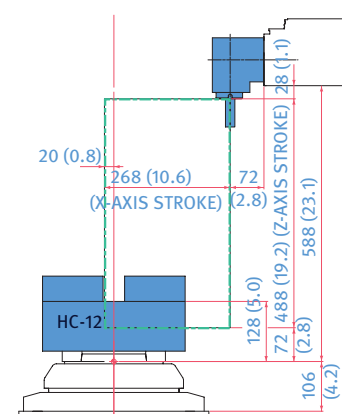

MACHINE SPECIFICATIONS

PUMA V400 series

Description		Unit	PUMA V400	PUMA V400M	PUMA V400P	PUMA V400-2SP
Capacity	Swing over bed	mm (inch)	610 (24.0)			
	Swing over saddle	mm (inch)	500 (19.7)			
	Recom. turning diameter	mm (inch)	305 (12.0)			
	Max. turning diameter	mm (inch)	496 (19.5)	420 (16.5)	496 (19.5)	496 (19.5)
	Max. turning length	mm (inch)	461 (18.1)	400 (15.7)	461 (18.1)	461 (18.1)
	Chuck size	inch	12			
Travels	Travel distance	X-axis	268(10.6)			
		Z-axis	488 (19.2)			
		C-axis	360			
Feedrates	Rapid traverse	X-axis	20 (787.4)	20 (787.4)	24 (944.9)	20 (787.4)
		Z-axis	24 (944.9)	24 (944.9)	24 (944.9)	24 (944.9)
		C-axis	200			-
Spindle	Max. Spindle speed	r/min	3000			
	Max. spindle power (S6 25% / S6 60% / S1 cont.)	kW (Hp)	26/22/18.5 (34.9/29.5/24.8)			
	Max. spindle torque	N·m (ft·lbs)	864 (637.6)			
	Spindle nose	ASA	A2-8			
	Spindle bearing diameter (Front)	mm (inch)	130 (5.1)			
	Main spindle indexing angle (C-axis)	deg	-	0.001	-	-
Turret	No. of tool stations	ea	12{8}	12	12	12+12{8+8}
	OD tool size	mm (inch)	25 x 25 (1.0 X 1.0)			
	Turret Indexing time(1st swivel)	sec	0.15			
	Rotary tool spindle speed	r/min	-	4000	-	-
	Rotary tool spindle motor	kW (Hp)	-	3.7/2.2 (5.0/3.0)	-	-
Power Source	Electric power supply (rated capacity)	kVA	40.26	44.66	44.66	77.01
Machine dimensions	Length x Width	mm (inch)	1475 x 2075 (58.1 X 81.7)			2910 x 2075 (114.6 X 81.7)
	Height	mm (inch)	3210 (126.4)			
	Weight	kg (lb)	6000 (13227.5)			12000 (26455.1)
Control	NC system	DOOSAN Fanuc i Plus				

WHY DOOSAN?

The Doosan promise, MACHINE GREATNESS, has two important meanings. The first is simple: Doosan makes great machines. The second is a challenge to our end-users. With a product line that is this comprehensive, accurate and reliable, we equip our customers to machine greatness.

The big question: *Why should you choose Doosan over other options?* Here's why...



**MACHINE
GREATNESS™**



Doosan Machine Tools

WHAT YOU MAKE AND HOW YOU MAKE IT MATTERS—SO MAKE IT GREAT WITH DOOSAN.

UNBEATABLE MACHINES

You won't find a more comprehensive range or a better combination of value, performance and reliability anywhere else.

ROBUST PRODUCT LINE

We offer an impressive range of machine models and hundreds of configurations. Whatever your machining needs and requirements, there's a Doosan for you.

READILY AVAILABLE - ANYWHERE IN THE WORLD

Machining centers (including 5-axis machines), lathes, multi-tasking turning centers and mill-turn machines, and horizontal borers with best-in-class specifications are all available...ready to install.

EXPERT SERVICE

Our dedicated, experienced and knowledgeable team is totally committed to improving your productivity, growth and success.

RESPONDING TO CUSTOMERS ANYTIME, ANYWHERE

Doosan Machine Tools' Global Network

Doosan Machine Tools provides systems-based professional support services, before and after the machine tool sale, by responding quickly and efficiently to customers. By supplying spare parts, product training, field service and technical support, we provide the expert care, attention and assistance our customers expect from a market leader.

Global sales and service support network		51	Technical centers Technical center, Sales support, Service support, Parts support
4	Corporations	200	Service posts
167	Dealer networks	3	Factories



CUSTOMER SUPPORT AND SERVICES

We're there for you whenever you need us.

We help our customers operate at maximum efficiency by providing them with a range of tried, tested and trusted services - from pre-sales consultancy to post-sales support.



Field services

- On-site service
- Machine installation and testing
- Scheduled preventive maintenance
- Machine repair service



Parts supply

- Supplying a wide range of original Doosan spare parts
- Parts repair service



Training

- Programming, machine setup and operation
- Electrical and mechanical maintenance
- Applications engineering



Technical support

- Supports machining methods and technology
- Responds to technical queries
- Provides technical consultancy



Head Office

22FT Tower, 30, Sowol-ro 2-gil
Jung-gu, Seoul, Korea, 04637

Tel +82-2-6972-0370/0350
Fax +82-2-6972-0400

Doosan Machine Tools America

19A Chapin Road, Pine Brook
New Jersey 07058, United States

Tel: +1-973-618-2500
Fax: +1-973-618-2501

Doosan Machine Tools Europe

Emdener Strasse 24, D-41540
Dormagen, Germany

Tel: +49-2133-5067-100
Fax: +49-2133-5067-111

Doosan Machine Tools India

No.82, Jakkuar Village
Yelahanka Hobil, Bangalore-560064

Tel: + 91-80-2205-6900
E-mail: india@doosanmt.com

Doosan Machine Tools China

Room 101,201,301, Building 39 Xinzhuan
Highway No.258 Songjiang District
China Shanghai (201612)

Tel: +86 21-5445-1155
Fax: +86 21-6405-1472

Sales inquiry

sales@doosanmt.com

*For more details, please contact Doosan Machine Tools.

*Specifications and information contained within this catalogue may be changed without prior notice.

*Doosan Machine Tools Co., Ltd. is a subsidiary of MBK Partners. The trademark **DOOSAN** is used under a licensing agreement with Doosan Corporation, the registered trademark holder.