



HIGH PRODUCTIVITY
COMPACT VERTICAL MACHINING CENTER

DNM

4000



DN SOLUTIONS

DNM 4000

The DNM 4000 is a compact vertical machining center with a 400mm Y-axis stroke and a directly-coupled 40 taper spindle. By reducing the machine's width, the footprint has been minimized but productivity, owing to the DNM 4000's high acceleration/deceleration rates, has been increased.





EASY OPERATOR ACCESS AND EXCELLENT CHIP DISPOSAL

- Designed with two doors for easy operator access to the working area.
- Bed flushing occurs on both left and right sides to optimize chip removal. This is especially useful when high chip volumes are produced.

STANDARD DIRECTLY-COUPLED SPINDLE FOR HIGHER PRODUCTIVITY

- The directly-coupled spindle reduces vibration and noise, thereby improving the machine's performance and environmental-friendliness
- Higher productivity is achieved by improving and increasing the machine's acceleration/ deceleration rates

AN ENVIRONMENTALLY-FRIENDLY MACHINE DESIGNED FOR RELIABLE AND EASY OPERATION

- Thermal error compensation function incorporated as standard.
- The Easy Operation function (Ez work) can be viewed in the pop-up window of the main NC screen for convenient machine operation.
- Grease lubrication for the roller guideways is a standard feature and is a cleaner, greener, more efficient and more cost-effective lubrication system.

BASIC STRUCTURE

The DNM 4000 is a compact, high-productivity vertical machining centre with a #40 spindle delivering outstanding cutting performance.

Travel distance

X axis

520 mm 20.5 inch

Y axis

400 mm 15.7 inch

Z axis

480 mm 18.9 inch

CNC system

- DN Solutions FANUC i
- SIEMENS

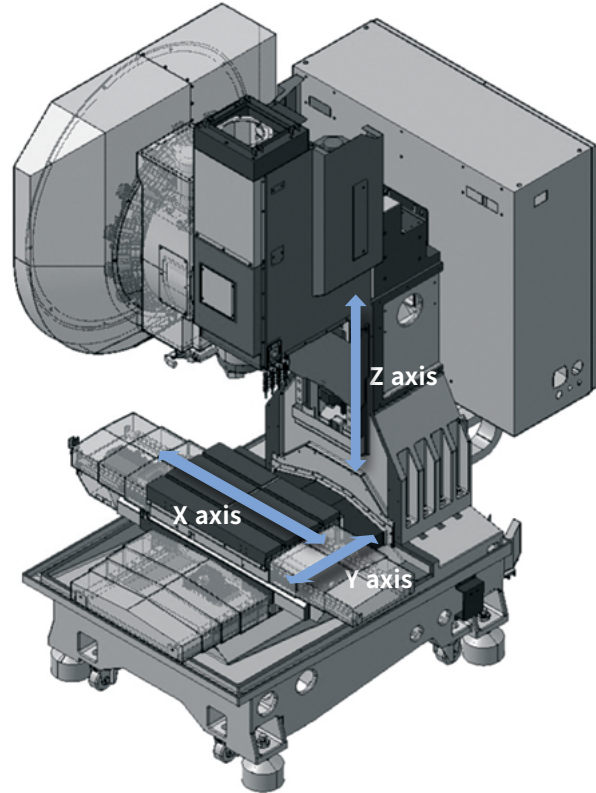

Axis system

Environmentally-friendly grease lubrication is used as standard for the axis feed system, and Roller-type LM Guideways enhance rigidity.

Rapid traverse rate (X / Y / Z axis)

48 m/min

1889.8 ipm

Roller-type LM guides are provided as a standard feature

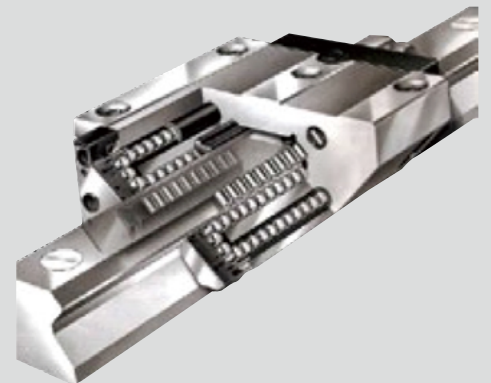

Grease lubrication for all axes is a standard feature

Grease lubrication system

The standard grease lubrication system eliminates the need for an oil skimmer and reduces lubrication costs by about 60% compared to oil lubrication.

Yearly maintenance cost

Max. **60%**



SPINDLE | TABLE | TOOL CHANGE SYSTEM

Directly-coupled spindles, with the dual contact tool and spindle interface, are a standard feature and help reduce vibration and noise whilst enhancing productivity, the working environment and machining accuracy. An increase in table size and the maximum load capacity, over the previous model, improves the machine's flexibility and application potential.

Dual contact tool system support as standard.

Max. spindle speed

FANUC / SIEMENS

12000 r/min

Max. spindle motor power

 FANUC / SIEMENS

18.5 kW / 16.5 kW
24.8 Hp / 22.1 Hp

Max. spindle motor torque

 FANUC / SIEMENS

117 N.m / 141 N.m
86.3 ft-lbs / 104.1 ft-lbs

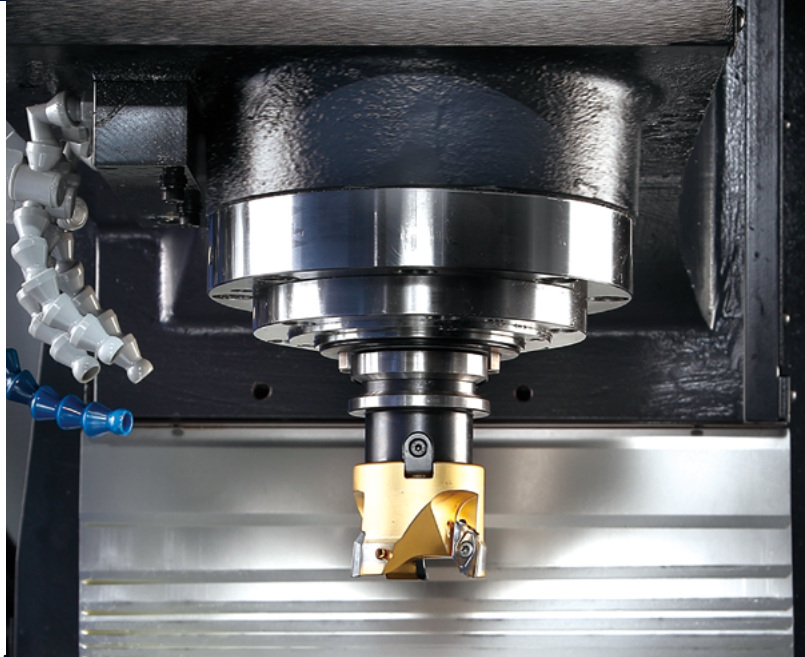

Max. weight on Table

400 kg 881.8 lb

Table size (A x B)

650 x 400 mm
25.6 x 15.7 inch

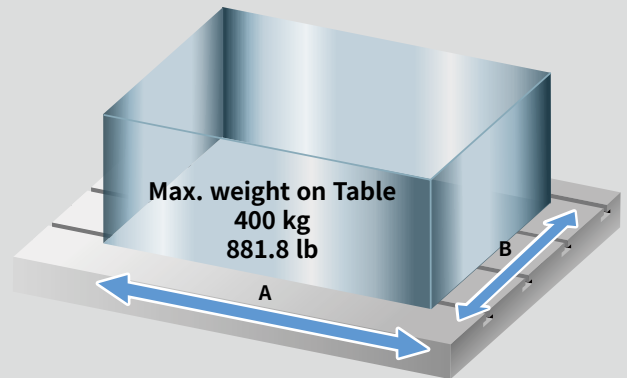

Tool Change System (ATC)

The highly-reliable tool magazine can accommodate up to 20 tools as standard.

Tool storage capacity

20 ea

Tool-to-Tool time

1.3 sec

Chip-to-Chip* time

2.6 sec

* The Chip-to-Chip time has been tested in accordance with DN Solutions's strict testing conditions, but may vary depending on different conditions.

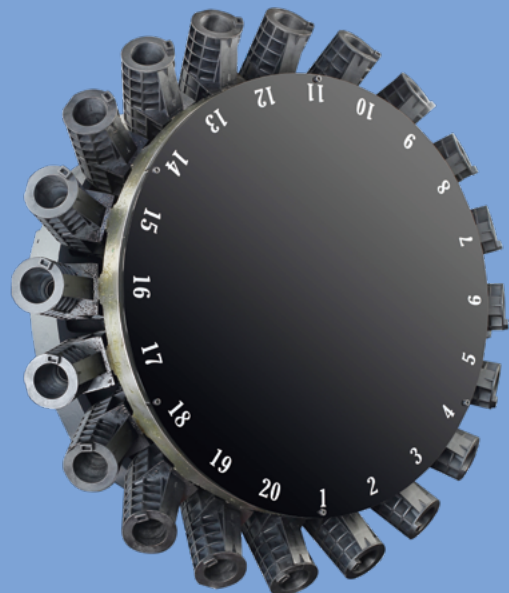

MACHINING PERFORMANCE

The machine's highly rigid structure with the 40 taper spindle ensures the best machining performance in its class.

Cutting performance

High-rigidity machining can be undertaken with speed and precision.
12000r/min, Direct, 18.5/11kW (24.8/14.8 Hp)

Face mill (ø80mm) Carbon steel (SM45C)			
Chip removal rate cm ³ /min (inch ³ /min)	Spindle speed r/min	Feedrate mm/min (ipm)	
596 (36.4)	1500	2700 (106.3)	
Face mill (ø80mm) Aluminium(AL6061)			
Chip removal rate cm ³ /min (inch ³ /min)	Spindle speed r/min	Feedrate mm/min (ipm)	
2016 (123.0)	1500	6300 (248.0)	
Drill (ø50 mm) Carbon steel (SM45C)			
Chip removal rate cm ³ /min (inch ³ /min)	Spindle speed r/min	Feedrate mm/min (ipm)	
530 (32.3)	1500	270 (10.6)	
Tap Carbon steel (SM45C)			
Tap size mm (inch)	Spindle speed r/min	Feedrate mm/min (ipm)	
M36 (1.4) x P4.0	221	884 (34.8)	
M3 (0.1) x P0.5	3000	1500 (59.1)	

* The results, indicated in this catalogue, are provided as examples only. They may not always be achieved owing to different cutting and environmental conditions.

High Productivity



Material : Aluminium (AL6061)

	Non-cutting time	Cutting time	Run hours
Previous model	3 min. 27 sec.	6 min. 22 sec.	9 min. 49 sec.
	Reduced by 17%		Reduced by 7%
DNM 4000	2 min. 52 sec.	6 min. 19 sec.	9 min. 11 sec.

* The results, indicated in this catalogue, are provided as examples only. They may not always be achieved owing to different cutting and environmental conditions.

STANDARD | OPTIONAL SPECIFICATIONS

Various optional features are available to meet customers' specific machining requirements and applications.

Description	Features		DNM 4000	
Spindle	12000 r/min	Direct 18.5/11 kW (24.8/14.8 Hp)	●	
Spindle cooling system (Oil cooler)	12000 r/min	Direct	○	
Magazin	Tool storage capacity	20 ea	●	
Tool shank type	ISO #40	BIG PLUS BT40	●	
		BIG PLUS CAT40	○	
		BIG PLUS DIN40	○	
Coolant	Flood coolant	0.69 MPa (1.8 kW)	●	
	TSC	None	●	
		2 MPa (1.5kW)	○	
	Flushing/Shower	Flushing coolant	0.10 MPa (1.1 kW)	●
		Flushing /Shower coolant	0.30 MPa (1.8 kW)	○
	Oil skimmer	Belt type	○	
MQL		○		
Chip disposal	Chip pan		●	
	Chip conveyor	Hinged type(Rear)	○	
		Magnetic scraper type(Rear)	○	
	Chip bucket	CAPACITY	220 L (58.1 gallon)	○
			300 L (79.3 gallon)	○
			380 L (100.4 gallon)	○
TYPE		ROTATION	○	
		FORKLIFT	○	
Precision machining options	AICC II (200block)		●	
	SSP (Smooth Surface Package)		○	
Measurement & Automation	Automatic tool measurement	TS27R	○	
	Automatic tool breakage detection		○	
	Automatic workpiece measurement	OMP60	○	
	Automatic front door with safety device		○	
Accessories	WORK LIGHT	LED LAMP	●	
	OPERATOR CALL LAMP	3-COLOR SIGNAL TOWER(LED)	●	
	LEVELING BLOCK & BOLT	-	●	
	SMART THERMAL CONTROL	SENSORLESS TYPE(ONLY SPINDLE)	●	
	ASSEMBLY & OPERATION TOOLS KIT	-	●	
	4TH AXIS PREPARATION CABLING FOR SERVO/1-PNEUMATIC PIPING	FACTORY READY MADE	●	
	AIR GUN		○	
	Air blower		○	
	Coolant gun		○	
	Mist collector		○	
Customized special option	ANCHORING ⁽¹⁾	SLIDE CLAMP & CHEMINCAL ANCHOR BOLT	○	
	TSA ⁽²⁾	0.54	○	
	ATC AUTO SHUTTER	20 TOOL	○	
	RASING BLOCK	150 mm	○	
		200 mm	○	
		300 mm	○	
	SCALE	SCALE BUILT-IN LM GUIDE	○	
	DRUM CHIPCONVEYOR	HINGE TYPE	○	
		SCRAPER TYPE	○	
	OIL LUBRICATION	X, Y, Z AXIS	○	
	20 BAR TSC with INVERTER	50Hz → 60Hz	○	
	AUTO TOOL LENGTH MEASUREMENT	RENISHAW / LTS	○	
AUTO TOOL BREAKAGE DETECTION	MSC/BK9(NEEDLE TYPE ON MAGAZINE)	○		

* Please contact DN Solutions for detailed specification information.

● Standard ○ Optional X Not applicable

(1) Please refer to foundation drawing in relation to anchoring. If more detail information want, consult with DN Solutions service

(2) In case of TSC is not required and only TSA is needed, this option can be selected.

 **Fire Safety Precautions** | There is a high risk of fire when using non-water-soluble cutting fluids, processing flammable materials, neglecting the controlled and careful use of coolants and modifying the machine without the consent of the manufacturer. Always check the SAFETY GUIDELINES carefully before using the machine.

PERIPHERAL EQUIPMENT

Oil Cooler option

An oil cooler correlated to room temperature can be equipped for a long-term operation at high speed. Cooling oil circulates around the spindle bearings to prevent thermal error of the spindle and maintain machining accuracy.



Raised column option

When the distance between the table top and the spindle nose has to be extended to accommodate, for example, a rotary table or fixture on the table, a raised column can be used.

Height
150/200/300 mm
 5.9 / 7.9 / 11.8 inch

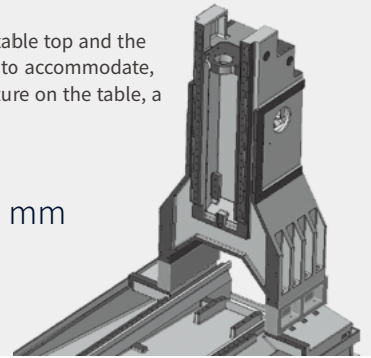

Chip conveyor option

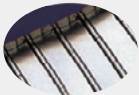

Hinged type



Magnetic scraper

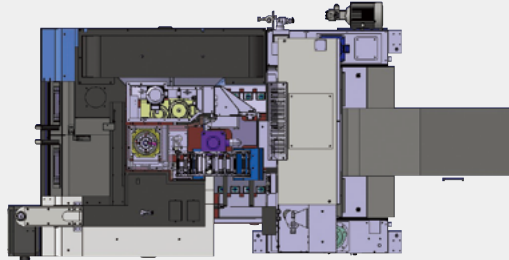

Chip pan

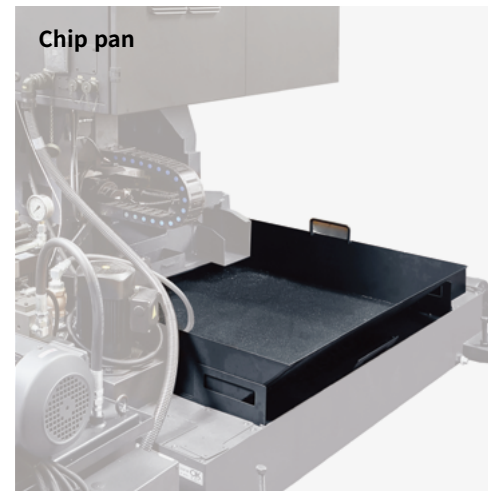

Chip conveyor type	Material	Description
Hinged belt	Steel	Hinged belt chip conveyor, which is most commonly used for steel work [for cleaning chips longer than 30mm(1.2inch)], is available as an option.
Magnetic scraper	Cast Iron	Magnetic scraper type chip conveyor, which is ideal for die-casting work [for cleaning small chips], is available as an option.

Hydraulic / Pneumatic fixture line option

The user should prepare pipelines for hydraulic/pneumatic fixtures whose detailed specifications should be determined by discussion with DN Solutions.

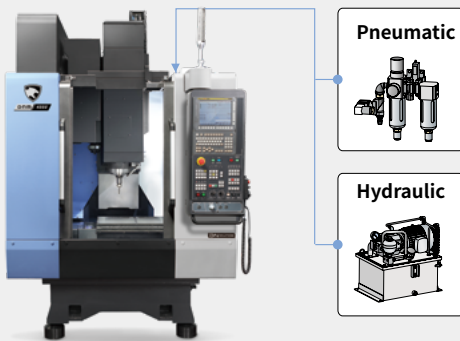

Auto shutter option

An auto shutter is included to prevent chips from entering the tool magazine during high speed machining of Aluminium parts.

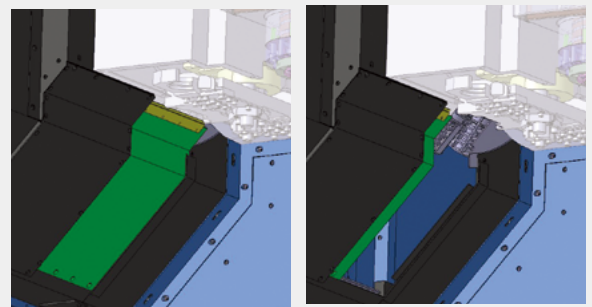

AWC system option

The optimized solution to realize compact automation system through automatic work-piece change system.

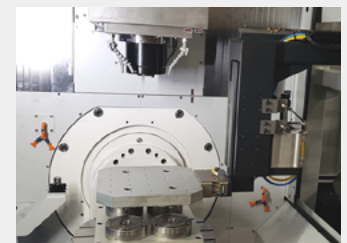
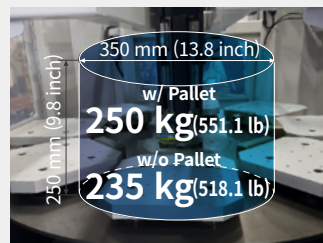

DN SOLUTIONS FANUC i PLUS

DN Solutions Fanuc i Plus is optimized for maximizing customer productivity and convenience.

15 inch screen + new operation panel

DN Solutions Fanuc i Plus' operation panel enhances operating convenience by incorporating common-design buttons and layout, and features the Qwerty keyboard for fast and easy operation.

DN Solutions Fanuc i Plus

- 15 inch color display
- Intuitive and user-friendly design

USB & PCMCIA card

QWERTY keyboard

- EZ-guide i standard
- Ergonomic operator panel
- 2MB Memory
- Hot key



iHMI touchscreen option

iHMI provides an intuitive interface that uses a touchscreen for quick and easy operation.

Range of applications

Providing various applications related to planning, machining, improvement and utility, for customer convenience.

NUMERIC CONTROL SPECIFICATIONS

FANUC

Item	Specifications	DN Solutions Fanuc i (0i Plus) DNM 4digit
Controlled axis	Controlled axes	3 (X,Y,Z)
	Simultaneously controlled axes	4 axes
Data input/output	Additional controlled Axis	●
	Fast data server	○
	Memory card input/output	●
	USB memory input/output	●
	Large capacity memory(2GB)*2	○
Interface function	Available Option only with 15" Touch LCD (iHMI Only) *2)	○
	Embedded Ethernet	●
	Fast Ethernet	○
Operation	Enhanced Embedded Ethernet function	●
	DNC operation	Included in RS232C interface.
	DNC operation with memory card	●
Program input	Workpiece coordinate system	●
	Program input	G52 - G59
	Addition of workpiece coordinate system	G54.1 P1 X 48 (48 pairs)
	Tool number command	●
Feed function	Tilted working plane indexing command	T4 digits
	AI contour control I	○
	AI contour control II	X
	AI contour control I	G5.1 Q_, 40 Blocks
	AI contour control II	G5.1 Q_, 200 Blocks
	AI contour control II	G5.1 Q_, 600 Blocks
Operation guidance function	AI contour control II	G5.1 Q_, 1000 Blocks *1)
	High smooth TCP	X
	EZ Guidei (Conversational Programming Solution)	X
	iHMI with Machining Cycle	●
Setting and display	EZ Operation package	X
	CNC screen dual display function	●
Network	FANUC MTConnect	●
	FANUC OPC UA	⊕
Others	Display unit	⊕
	10.4" color LCD	X
	15" color LCD	X
	15" color LCD with Touch Panel	●
	640M(256KB)_500 programs	X
	1280M(512KB)_1000 programs	X
	2560M(1MB)_1000 programs	X
	5120M(2MB)_1000 programs	●
	10240M(4MB)_1000 programs	X
	20480M(8MB)_1000 programs	X
	2560M(1MB)_2000 programs	X
	5120M(2MB)_4000 programs	X
	10240M(4MB)_4000 programs	X
	20480M(8MB)_4000 programs	X
Part program storage size & Number of registerable programs	X	

*1) The number of look-ahead blocks may be changed or limited depending on the peripheral device or the configuration of the internal NC system.

*2) Available Option only with Fanuc i plus iHMI

● Standard ○ Optional X N/A ⊕ Available
Network: FANUC MT Connect and FANUC OPC UA available.

DN SOLUTIONS FANUC I PLUS

EZ-Guide i

Using the DN Solutions EZ-Guide i, users can create a cutting program for any desired shape, including patterns, by entering the appropriate figures only.

Exemplary Programming : Cutting shape

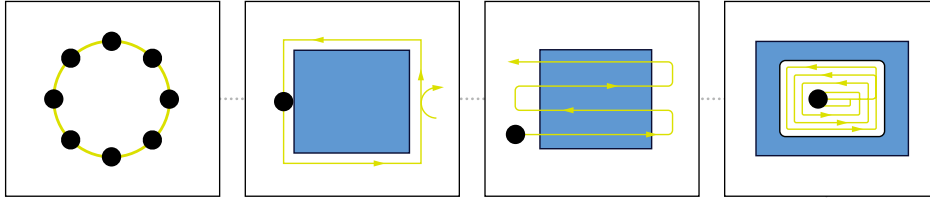

Collet Chuck

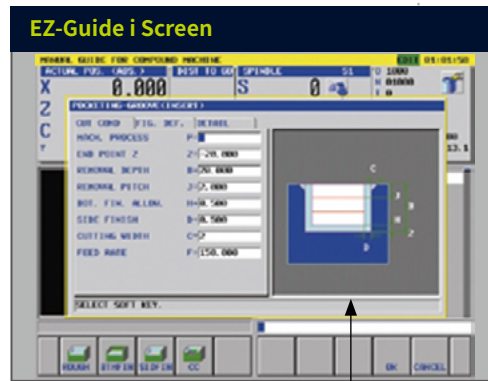
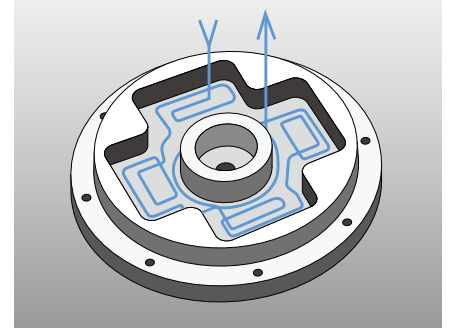

Enter the dimensions of the desired shape.

Automatic creation of cutting program

```
O7000 (SAMPLE PROGRAM) ;
...
M3 S1500 ;
G0 X50. Y125. ;
G0 Z30. ;
G1040 T0.5 J3. H0.2 K0.5 ... ;
G1020 H120. V50. U37. W68. ... ;
G0 Z80. ;
M5 ;
```

A cutting program is automatically created with the entered values.

Ez work

The software developed by DN Solutions provides a range of different functions designed for fast, efficient and convenient operation

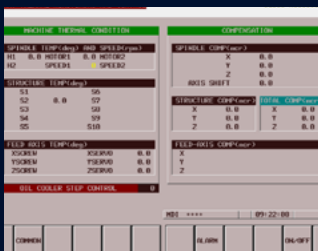

Thermal Compensation

A function to maintain high-precision machining quality by analyzing and correcting the amount of thermal displacement of a structure through a temperature sensor



M/G-Code List

Functional description of M code and G code



Tool Management

Function to manage tool information [Tool information / Tool No. / Tool condition (normal, large diameter, worn / damaged, used for the rst time, manual) / Tool name]

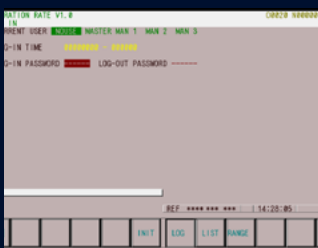

Operation Rate

Machine operation history management function by date based on load



Adaptive Feed Control

Function to control feedrate so that the cutting can be carried out at a constant load (To adapt to the spindle load set up with constant load feedrate control function)



Spindle Warm Up

A function that assists spindle warm-up for spindle life when the spindle has not been used for a certain period of time

CONVENIENT OPERATION

SIEMENS 828D

15.6" screen + new operation panel

The newly-designed operation panel improves the customer convenience by incorporating and using common-design buttons and layouts, and includes the familiar QWERTY keyboard for fast and easy operation.

- 15.6" display
- 10MB high capacity user memory
- USB & ethernet (standard)
- QWERTY keyboard (standard)
- High-speed calculation and simulation can be fulfilled by improved processor functionality



Conversational convenient function

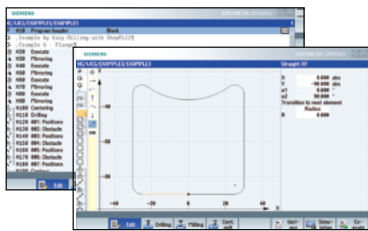

Shop Mill Part Programming

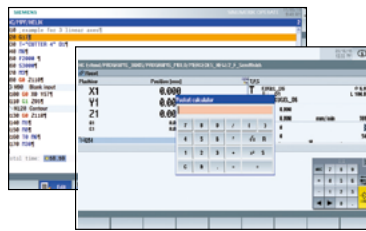

Smart function

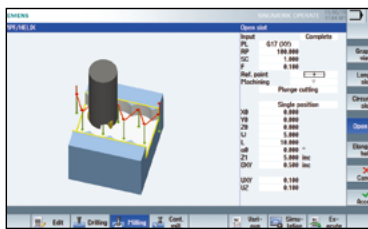

Advanced program language programGUIDE

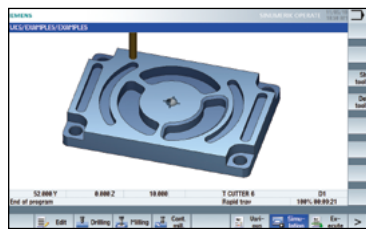

Simulation and machining contour monitoring

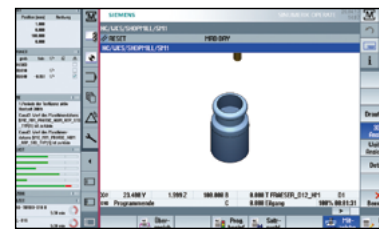

Side screen widget

NUMERIC CONTROL SPECIFICATIONS

SIEMENS

Item	Specifications	S828D
		DNM
Controlled axis	Controlled axes (제어축수)	-
	Simultaneously controlled axes (동시 제어축수)	3축
Data input/output	Memory card input/output	-
	USB memory input/output	(Local drive)
Interface function	Ethernet	X
		(X130)
Operation	On network drive	●
	On USB storage medium, e.g. memory stick	(without EES option, Extcall)
Program input	Workpiece coordinate system	○
	Addition of workpiece coordinate system	(without EES option, Extcall)
Interpolation & Feed function	Advanced surface	●
	Top surface	○
Programming & Editing function	Look ahead number of block	S/W version 4.8
	3D simulation, finished part	450
Operation Guidance Function	Simultaneous recording	●
	Measure kinematics	●
Setting and display	DXF Reader for PC integrated in SINUMERIK Operate	X
	ShopMill	○
Network	EZ Work	●
	Operation via a VNC viewer	●
Etc. function	MTCConnect	●
	OPCUA	○
Etc. function	15.6" color display with touch screen	●
	19" color display without touch screen	X
	21.5" color display with touch screen	X
	CNC user memory	10 MB
	Expansion by increments	2 ~ 12 MB
	Collision avoidance	○
Collision avoidance ECO (machine, working area)	X	

POWER | TORQUE | TABLE DIMENSION

FANUC

MAX. SPINDLE SPEED

12000 r/min

MAX. SPINDLE POWER

18.5/11 kW 24.8/14.8 Hp

MAX. SPINDLE TORQUE

117 N·m 86.3 ft-lbs

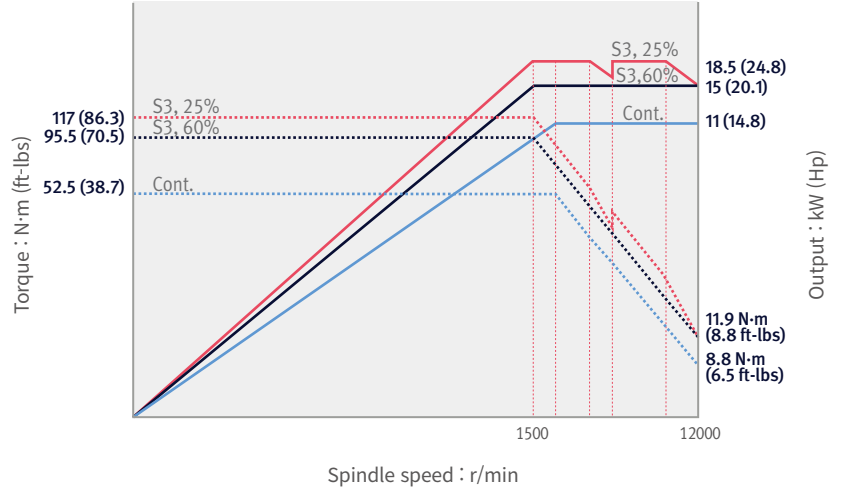

SIEMENS

MAX. SPINDLE SPEED

12000 r/min

MAX. SPINDLE POWER

16.5/11 kW 12.2/14.8 Hp

MAX. SPINDLE TORQUE

141.3 N·m 104.3 ft-lbs

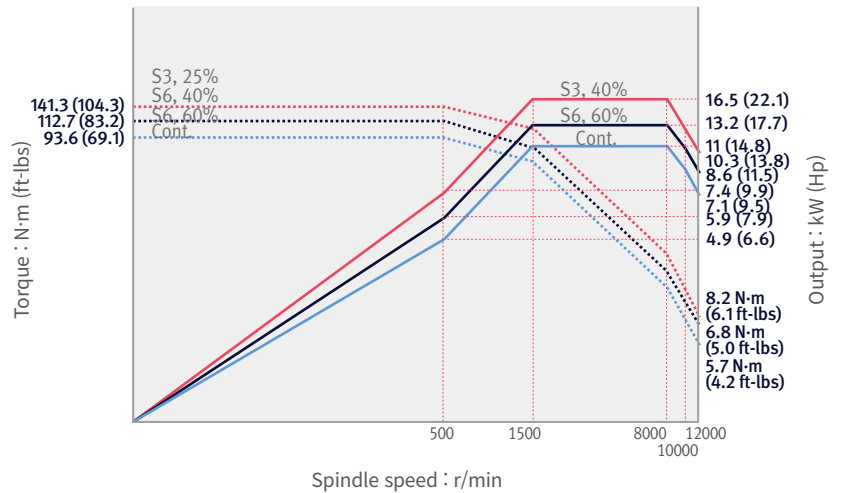

TABLE

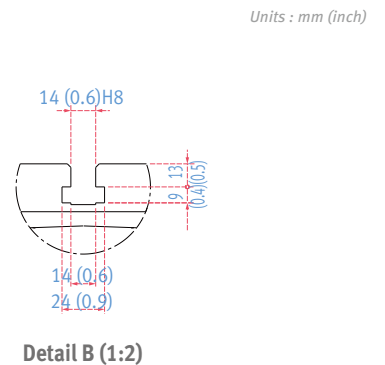
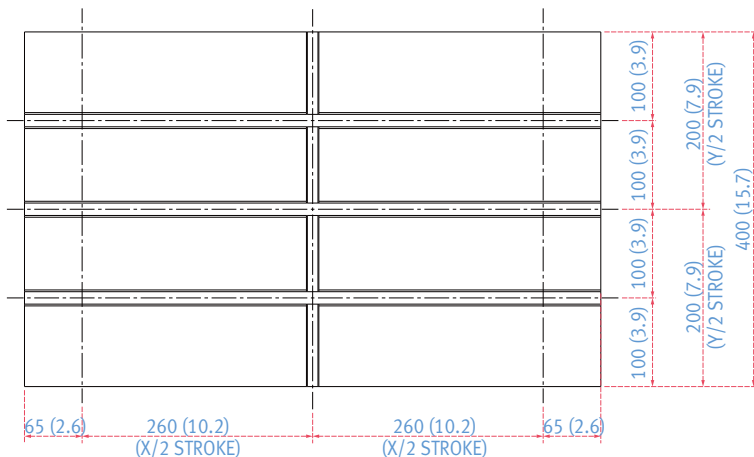

Units : mm (inch)

DIMENSIONS

Units : mm (inch)

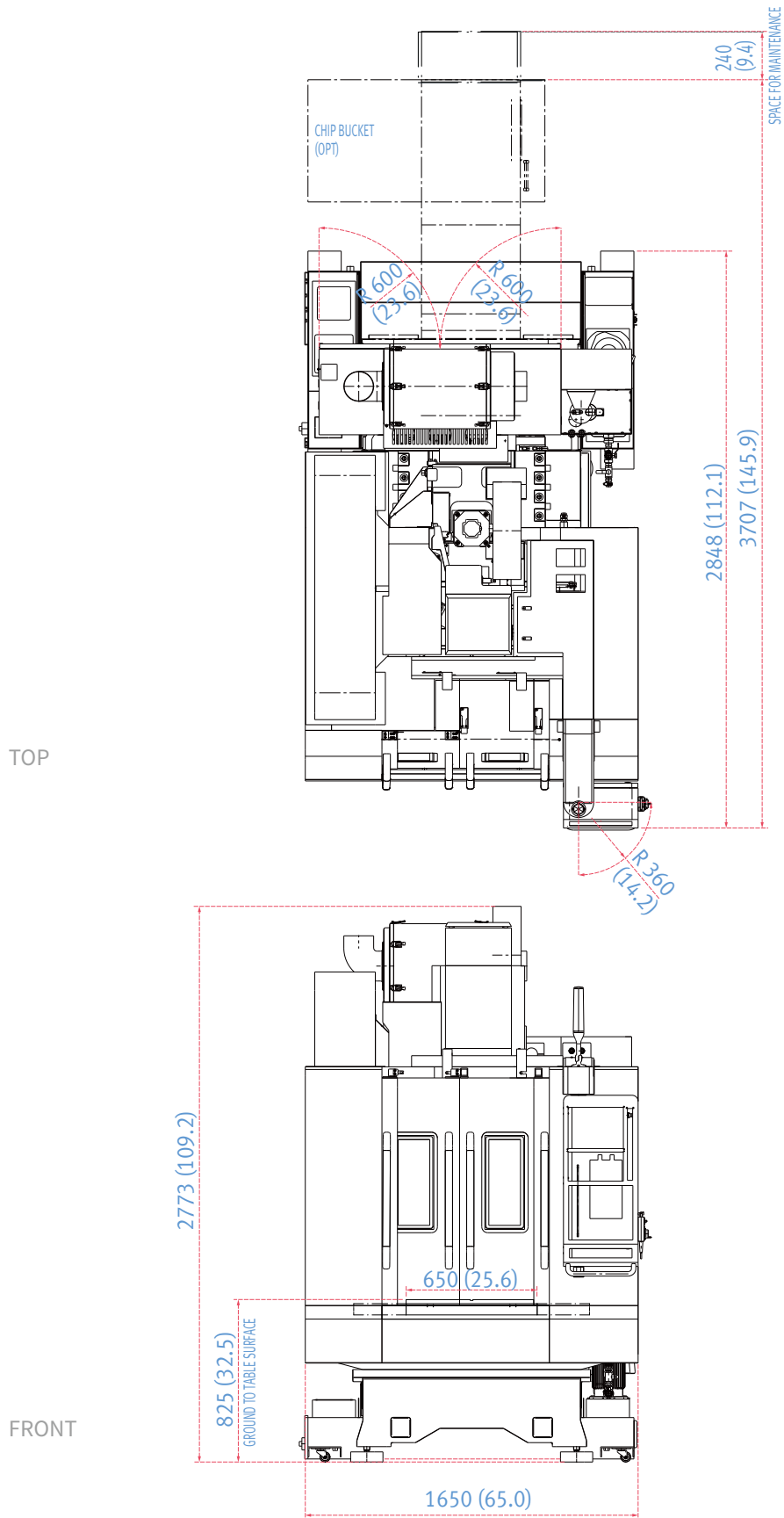

* Some peripheral equipment can be placed in other places

MACHINE SPECIFICATIONS

Description		Unit	DNM 4000
Travels	Travel distance	X axis	mm (inch) 520 (20.5)
		Y axis	mm (inch) 400 (15.7)
		Z axis	mm (inch) 480 (18.9)
	Distance from spindle nose to table top		mm (inch) 150 ~ 630 (5.9~24.8)
Table	Table size		mm (inch) 650 x 400 (25.6 x 15.7)
	Table loading capacity		kg (lb) 400 (881.8)
	Table surface type		mm (inch) T-SLOT (3-100(3.9) x 14(0.6)H8)
Spindle	Max. spindle speed		r/min 12000
	Taper		- ISO #40
	Max. spindle power		kW (Hp) 18.5/11 (24.8/14.8)
	Max. spindle torque		N · m (ft-lbs) 117 (86.3)
Feedrates	Rapid traverse rate	X axis	m/min (ipm) 48 (1889.8)
		Y axis	m/min (ipm) 48 (1889.8)
		Z axis	m/min (ipm) 48 (1889.8)
Automatic Tool Changer	Type of tool shank	Tool shank	- BT 40 {CAT40/DIN40}* PS806
		Pull stud	-
	Tool storage capa.		ea 20
	Max. tool diameter	Continuous	mm (inch) 90 (3.5)
		Without adjacent tools	mm (inch) 125 (4.9)
	Max. tool length		mm (inch) 270 (10.6)
	Max. tool weight		kg (lb) 5 (11)
	Max. tool moment		N · m (ft-lbs) 9.8 (7.2)
	Tool selection		MEMORY RANDOM
	Tool change (Tool-to-Tool)		sec 1.3
	Tool change (Chip-to-Chip)		sec 2.6
Power source	electric power supply(rated capacity)		kVA 29.5
	Compressed air supply		Mpa (psi) 0.54 (78.3)
Tank capacity	Coolant tank capacity		L (gal) 200 (52.8)
Machine Dimensions	Height		mm (inch) 2753 (108.4)
	Length		mm (inch) 2853 (112.3)
	Width		mm (inch) 1650 (65.0)
	Weight		kg (lb) 3300 (7275.3)
Control	CNC system		- DN Solutions Fanuc i Plus

*{ } : Option

RESPONDING TO CUSTOMERS ANYTIME, ANYWHERE

DN Solutions Global Network

DN Solutions provides systems-based professional support services, before and after the machine tool sale, by responding quickly and efficiently to customers. By supplying spare parts, product training, field service and technical support, we provide the expert care, attention and assistance our customers expect from a market leader.

Global sales and service support network		51	Technical centers Technical center, Sales support, Service support, Parts support
4	Corporations	200	Service posts
156	Dealer networks	3	Factories



CUSTOMER SUPPORT AND SERVICES

We're there for you whenever you need us.

We help our customers operate at maximum efficiency by providing them with a range of tried, tested and trusted services - from pre-sales consultancy to post-sales support.



Field services

- On-site service
- Machine installation and testing
- Scheduled preventive maintenance
- Machine repair service



Parts supply

- Supplying a wide range of original DN Solutions spare parts
- Parts repair service



Training

- Programming, machine setup and operation
- Electrical and mechanical maintenance
- Applications engineering



Technical support

- Supports machining methods and technology
- Responds to technical queries
- Provides technical consultancy



dn-solutions.com

Head Office

22F T Tower, 30, Sowol-ro 2-gil
Jung-gu, Seoul, Korea, 04637

Tel: +82-2-6972-0370/0350
Fax: +82-2-6972-0400

DN Solutions America

19A Chapin Road, Pine Brook
New Jersey 07058, United States

Tel: +1-973-618-2500
Fax: +1-973-618-2501

DN Solutions Europe

Emdener Strasse 24, D-41540
Dormagen, Germany

Tel: +49-2133-5067-100
Fax: +49-2133-5067-111

DN Solutions India

No.82, Jakkuar Village
Yelahanka Hobli, Bangalore-560064

Tel: + 91-80-2205-6900
E-mail: india@dncompany.com

DN Solutions China

Room 101,201,301, Building 39 Xinzhuan
Highway No.258 Songjiang District
China Shanghai (201612)

Tel: +86 21-5445-1155
Fax: +86 21-6405-1472

Sales inquiry

sales@dncompany.com

* For more details, please contact DN Solutions.

* Specifications and information contained within this catalogue may be changed without prior notice.