



Full 5-axis, Y 1.1m, ϕ 1050mm Rotary Table

VCF

1100LSR



BASIC STRUCTURE

Table-fixed column moving structure, suitable for 5-axis complex processing of medium and large parts.

Travel distance

X axis **4000** mm (157.5 inch)

Y axis **1100** mm (43.3 inch)

Z axis **1200** mm (47.2 inch)

Rapid traverse rate

X axis **40** m/min (1574.8 ipm)

Y axis **40** m/min (1574.8 ipm)

Z axis **36** m/min (1417.3 ipm)

Z axis is supported by dual ball screw for more stable support.

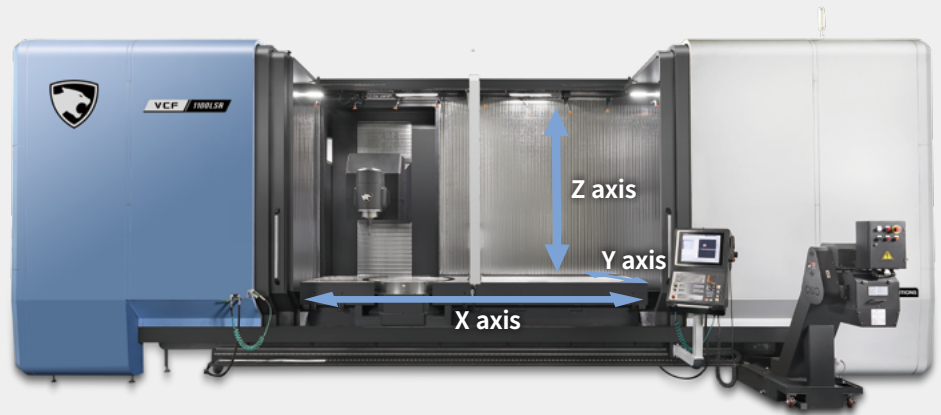

Axis system

Table-fixed column moving structure, suitable for 5-axis complex processing of medium and large parts.

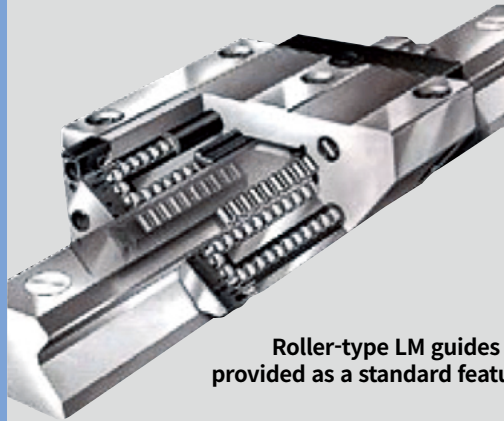

Roller-type LM guides are provided as a standard feature.

Linear scale

Applied the linear scale feedback system as a standard on X axis, accuracy of the machine can be further improved since the X axis can be controlled to correct positions.



ROTARY TABLE

For items requiring side processing and etc. Built-in rotary table is applied to enable various complex shape precision processing.

Diameter

1050 mm (41.3 inch)

Load capacity

2000 kg (4409.2 lb)

Rapid

20 r/min

Built-in structure, it offers wide range of specifications for machining up to $\phi 1500$ workpieces.

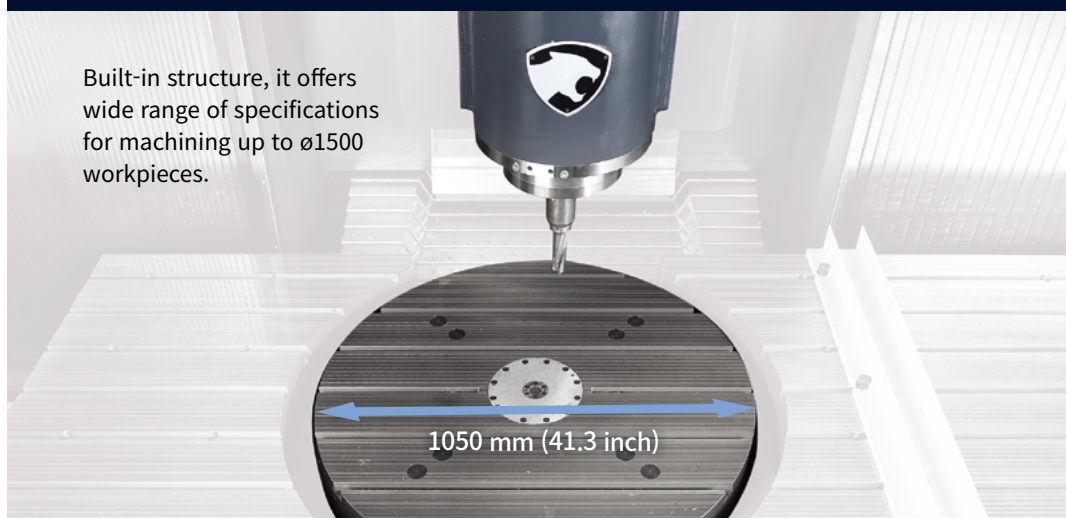

SPINDLE

Built-in spindle is applied to secure the rigidity and precision of the spindle.

Max. speed

10000 r/min

Spindle tool taper

ISO #50

Spindle tool taper

37/25 kW (49.6/33.5 Hp)

Max. torque

302 N.m (222.9 ft-lbs)

Swivel head

Roller Gear Cam structure for rotary table to secure high rigidity and precision

Automatic Tool Changer (ATC)

It is applied in a structure that does not affect the machining quality even during the operation of the magazine.

Tool storage capacity

60 ea

120 ea (60+60) option

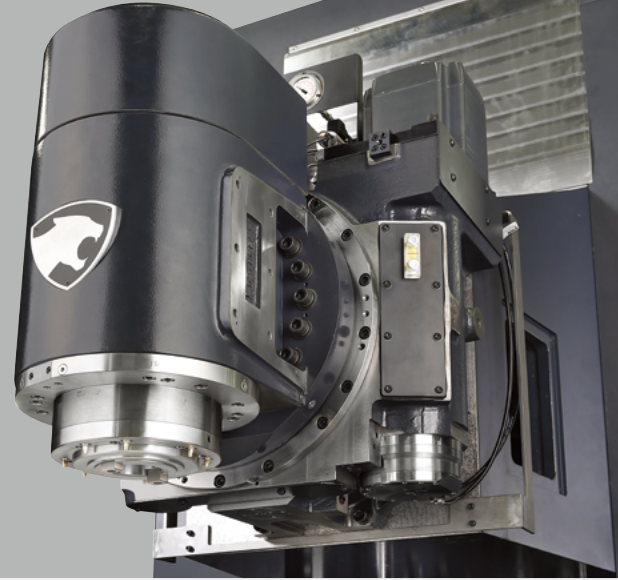

240° rotatable B axis

The 240° rotatable spindle is useful for milling of inclined surfaces.



Type	Axis	Speed (r/min)	Travel (deg)	Rotary encoder
Roller gear Cam (RGC)	B-axis	30	240 (+120, -120)	Standard

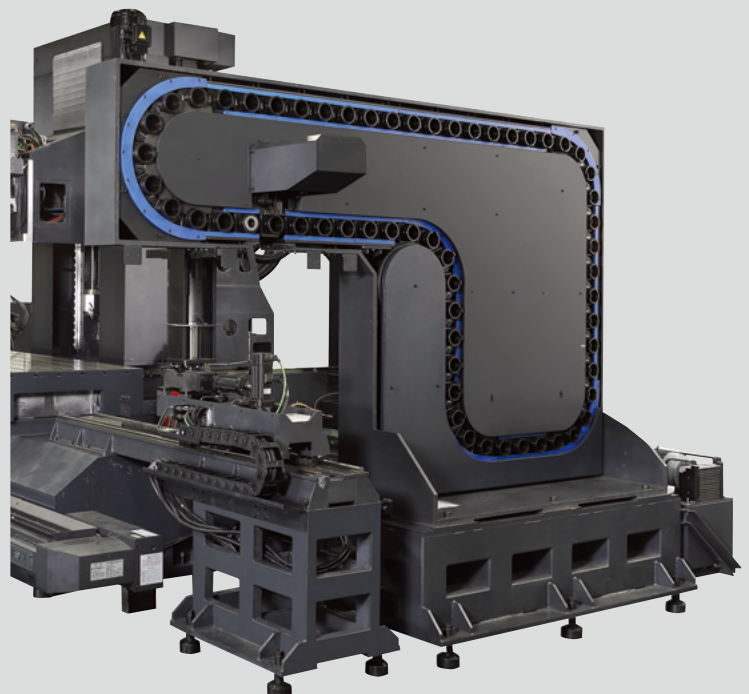



dn-solutions.com

Head Office

22F T Tower, 30, Sowol-ro 2-gil
Jung-gu, Seoul, Korea, 04637
Tel: +82-2-6972-0370/0350
Fax: +82-2-6972-0400

DN Solutions America

19A Chapin Road, Pine Brook
New Jersey 07058, United States
Tel: +1-973-618-2500
Fax: +1-973-618-2501

DN Solutions Europe

Emdener Strasse 24, D-41540
Dormagen, Germany
Tel: +49-2133-5067-100
Fax: +49-2133-5067-111

DN Solutions India

No.82, Jakkuar Village
Yelahanka Hobli, Bangalore-560064
Tel: + 91-80-2205-6900
E-mail: india@dncompany.com

DN Solutions China

Room 101,201,301, Building 39 Xinzhuan
Highway No.258 Songjiang District
China Shanghai (201612)
Tel: +86 21-5445-1155
Fax: +86 21-6405-1472

Sales inquiry

sales@dncompany.com

* For more details, please contact DN Solutions.

* Specifications and information contained within this catalogue may be changed without prior notice.